

# NightStar® CS Magnetic Force Flashlight

Thank you for purchasing NightStar CS (NSCS). We at Applied Innovative Technologies, Inc. are confident that you will find NightStar to be the most reliable and durable light source you have ever owned. To learn more about NSCS and other unique products please visit our website: [www.appliedinnotech.com](http://www.appliedinnotech.com)

## Instructions

To charge NightStar CS, shake the light so that the magnet quickly and completely passes through the wire coil. NSCS is most effectively recharged when it is turned off and shaken for 20 seconds at 4 shakes per second over a distance of approximately 1 inch (2.54 cm) (See Figure 1: **Note: it's mostly in the wrist...**). After each 20 second charge cycle rest for 5 seconds before starting the next cycle. On a full charge, NSCS will provide effective illumination for 20 minutes. Initially, the capacitor may be completely discharged. If this occurs, NSCS will require approximately 12 to 14 charge cycles (240 to 280 seconds of shaking) to fully recharge the capacitor. When NSCS is low on energy (at the point when the LED is barely lit) it will take approximately 6 charge cycles (120 seconds of shaking) to recharge the capacitor.

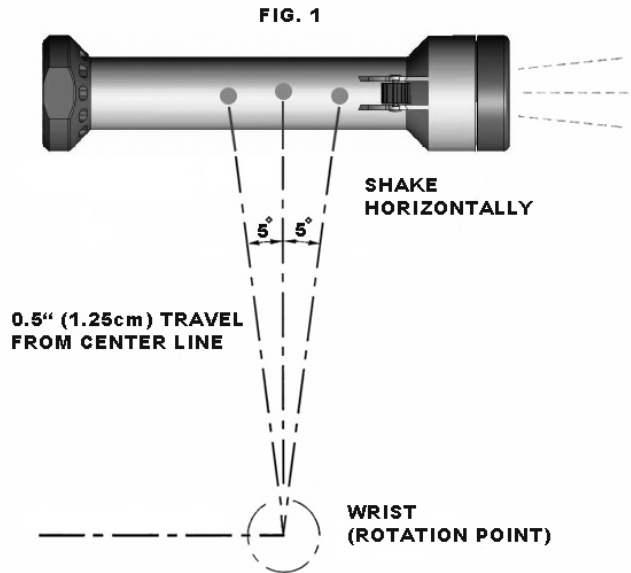

## Performance Optimization

Shaking NightStar CS as described above results in a resonant condition that maximizes recharge efficiency. When resonance is reached, it will require fewer shakes to fully charge the capacitor. At resonance you will feel and hear the magnet smoothly changing direction due to the motion of the light matching the recoil of the magnetic repulsion system. (Optimum shaking of NSCS is analogous to pumping your legs correctly on a swing.)

## WARNING

A STRONG MAGNETIC FIELD surrounds NightStar CS! Do not set NSCS within 16" (40cm) of computers, monitors, televisions, or magnetic storage media (cassette tapes, computer floppies, videotapes, credit cards, etc.). Increased distances may be necessary for highly sensitive compasses used in aircraft and boats. Exercise caution when using any magnetic device close to pacemakers. Applied Innovative Technologies, Inc. assumes no responsibility for damage to any magnetically sensitive component or magnetic storage media or consequences resulting from such damage. Applied Innovative Technologies, Inc. is not responsible for any damages, consequential or otherwise, resulting from the use of NSCS.



## Care

Use only warm water and mild soap to clean the housing. Rinse with fresh water. Do not use petroleum distillates (such as gasoline or kerosene) or solvents such as acetone to clean any part of the flashlight. Certain insect repellents may also act as a solvent. The lens can be cleaned with Windex or any similar glass-cleaning product.

## Additional Features

When horizontally suspended by a string or wire, NightStar CS will align in a north-south orientation, serving as a compass with the front of the light pointing towards north. NightStar's luminescent on/off switch contains a new extremely efficient light storing material. The switch will glow for several hours after only a few minutes of direct exposure to room or sunlight. This feature allows NSCS to be easily located and operated in dark environments.

## Specifications

### ELECTROMAGNETIC COMPATIBILITY

Conforms to Council Directive 89/336/EC. Measured RF levels are far below limits for all frequencies.

[ Tests Performed by Labein Laboratories ]

### SUBMERSION

Operational at an ocean depth of 160-ft (49m). [Equivalent pressure crush point: 69 PSI]

[ Tests Performed by Hauser Laboratories ]

### IMPACT RESISTANCE

Operational after repeated random drops from a height of 4-ft (1.2 m) onto a concrete surface.

[ Tests Performed by Hauser Laboratories ]

### TEMPERATURE

Storage: -50F (-45C) to 140F (60C)  
Operation: -40F (-40C) to 130F (55C)

[ Tests Performed by Hauser Laboratories ]

### CORROSION RESISTANCE

Operational after 3 days immersion in solutions of salt water, ammonia, phosphoric acid\*, motor oil and diesel fuel (\* 10% solution).

[ Tests Performed by Hauser Laboratories ]

### WEIGHT / MASS / LENGTH

5.4 ounces / 150 grams / 7" (17.8cm)

## Warranty

In the unlikely event that NightStar CS fails within 5 years of the date of purchase, we will repair or replace it at no cost. It is necessary to include your name and current address with the returned product. This warranty is void if failure is due to severe mishandling or abuse. Deliver your NSCS to: Applied Innovative Technologies, Inc. P.O. Box 754, Fort Lupton, Colorado 80621 USA. If you have questions please contact us at 303-857-1405.

To learn about other A.I.T. products please visit our website at [www.appliedinnotech.com](http://www.appliedinnotech.com). While there, please let us know how you found out about NightStar and what you think of our product by clicking on the Comments link. We greatly appreciate any feedback you provide!